



Euro-Clear Ltd.

Address: HU 9071, Gönyű, Kossuth Lajos street 65/A.

Tel: +36/96-544-240

Fax: +36/96-544-248

Email: contact@euro-clear.eu

Web: www.euro-clear.eu

Multi-functional Flow Control Valve for Water Treatment Systems

- 61202 (Old Model No.: F64B)
- 71202 (Old Model No.: F64C)
- 60202C (Old Model No.: F64BC)
- 61104 (Old Model No.: F64A1)
- 61204 (Old Model No.: F64A2)
- 61204C (Old Model No.: F64AC)
- 61206 (Old Model No.: F64F)
- 61210 ((Old Model No.: F64D)

Instruction Manual

Please read this manual in details before using the valve and keep it properly in order to consult in the future.

0WRX.466.524

Before the valve put into use, please fill in the below content so as to help us to refer in the future.

Softener system configuration

Tank Size: Dia. _____ mm, Height _____ mm;
Resin Volume _____ L; Brine Tank Capacity _____ L;
Hardness of Raw Water _____ mmol/L;
Pressure of Inlet Water _____ MPa;
Control Valve Model _____ ; Number _____ ;
Specification of Brine Line Flow Control _____ ;
Injector Model _____ ;
Water Source (Options): Ground Water ; Filtered Ground Water ;
Tap-water ; Others _____.

Parameter Set Manually

Backwash Time _____ min.; Brine & Slow Rinse Time _____ min.;
Brine Refill Time _____ min.; Fast Rinse Time _____ min.

● If there is no special requirement when purchasing product, we choose 3# injector and 3# drain line flow control for F64D and F64F; 9# injector and 5# drain line flow control for F64A and F64AC; and 5# injector and 3# drain line flow control for F64B and F64C.

Catalogue

Notice	
1. Product Overview	
1.1.Main Application & Applicability.....	
1.2.Product Characteristics	
1.3.Service Conditions	
1.4.Product Structure and Technical Parameters	
1.5.Installation	
2. Usage	
2.1.Hand Wheel.....	
2.2. Figure on Decoration Cover and its English Description	
3. Application	
3.1. Working Flow Chart.....	
3.2. System Configuration and Flow Rate Curve.....	
3.3. Parameter Settlement	
3.4.Trial Running	
3.5. Basic Usage	
3.6. Trouble-Shooting.....	
3.7. Assembly & Parts	
4. Warranty Card	

Notice

- To ensure normal operation of the valve, please consult with professional installation or repairing personnel before use it.
- If there are any of pipeline engineering and electric works, there must be finished by professional at the time of installation.
- Do not use the control valve with the water that is unsafe or unknown quality.
- Depending on the changing of working environment and water requirement, each parameter of softener should be adjusted accordingly.
- When the water treatment capacity is too low, please check the resin. If the reason is shortage of resin, please add; if the resin is turn to reddish brown or broken, please replace.
- Test water periodically to verify that system is performing satisfactorily.
- Sodium used in the water softening process should be considered as part your overall dietary salt intake. Contact doctor if you are on a low sodium diet.
- Ensure that there is solid salt all the time in the brine tank in the course of using, when this valve is used for softening. The brine tank should be added the clean water softening salts only, at least 99.5% pure, forbidding use the small salt.
- Do not put the valve near the hot resource or leave it outside.
- Forbidden to carry the injector body. Avoid to use injector body as support to carry the system.
- Forbidden to use the brine tube or other connectors as support to carry the system.
- Please use this product under the water temperature between 5~50℃、water pressure 0.15~0.6MPa. Failure to use this product under such conditions voids the warranty.
- If the water pressure exceeds 0.6Mpa, a pressure reducing valve must be installed before the water inlet. While, if the water pressure under 0.15MPa, a booster pump must be installed before the water inlet.
- Do not let children touch or play, because carelessness operating may cause the procedure changed.
- For demounting easily, please use strainer with male thread of M88×2 when installs N64D on the top.

1. Product Overview

1.1. Main Application & Applicability

Mainly used for softening or demineralization water treatment systems

Be suitable for

- Residential softening system
- Ion exchange equipment
- Boiler softening water system
- RO pretreatment softening system, etc.

1.2. Product Characteristics

➤ Simple structure and reliable sealing

It adopts hermetic head faces with high degree pottery and corrosion resistance for opening and closing. It combines with Service, Backwash, Brine & Slow Rinse, Brine Refill and Fast Rinse.

➤ No water pass the valve of single tank type in regeneration.

➤ Various methods for installation

The valve can be top-mounted and side-mounted (Should be used with the side-mounted connector).

➤ Handle alternatives: Metal and plastic

1.3. Service Conditions

Runxin Valve should be used under the below conditions:

Items		Requirements
Working conditions	Working pressure	0.15MPa~0.6MPa
	Water temperature	5°C~50°C
Working environment	Environment temperature	5°C~50°C
	Relative humidity	≤95% (25°C)

Inlet water quality	Turbidity	Down-flow regeneration < 5FTU ; Up-flow regeneration < 2FTU
	Hardness	First grade < 6.5mmol/L; Second grade < 10mmol/L
	Free chlorine	< 0.1mg/L
	Iron ²⁺	< 0.3mg/L
	CODMn	< 2mg/L (O ₂)

- When the water turbidity exceeds the conditions, a filter should be installed on the inlet of control valve.
- When the water hardness exceeds the conditions, the outlet water hardness will hardly reach the requirement of boiler feed water (0.03 mmol/L) . It is suggested to adopt second grade softener.

1.4.Product Structure and Technical Parameters

A. Appearance and dimension (The appearance is just for reference. It is subjected to the real product.)

F64A/F64B/F64C

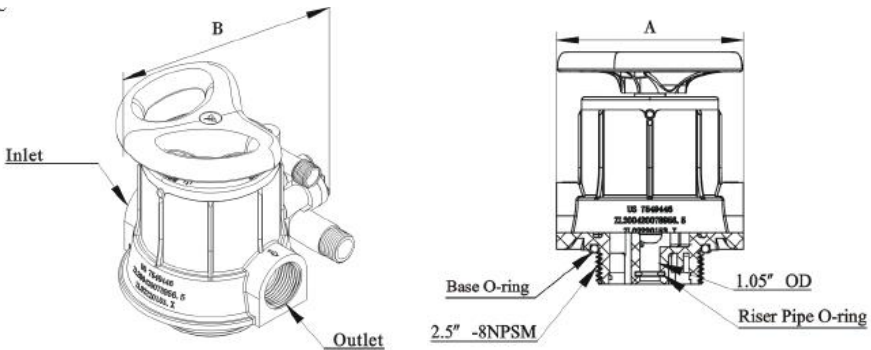

N64D/N64F

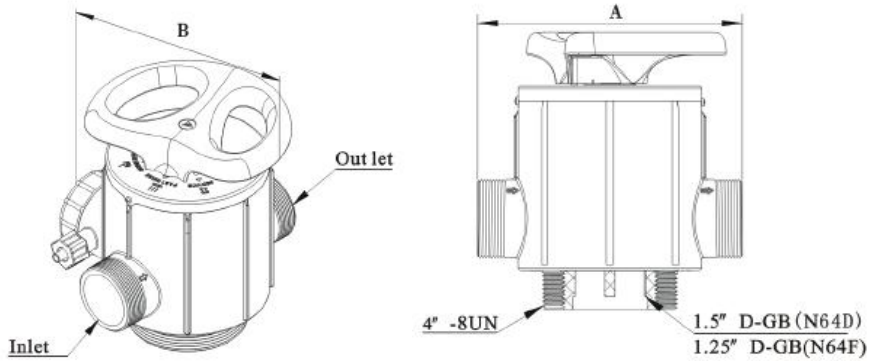

F64BC/F64AC

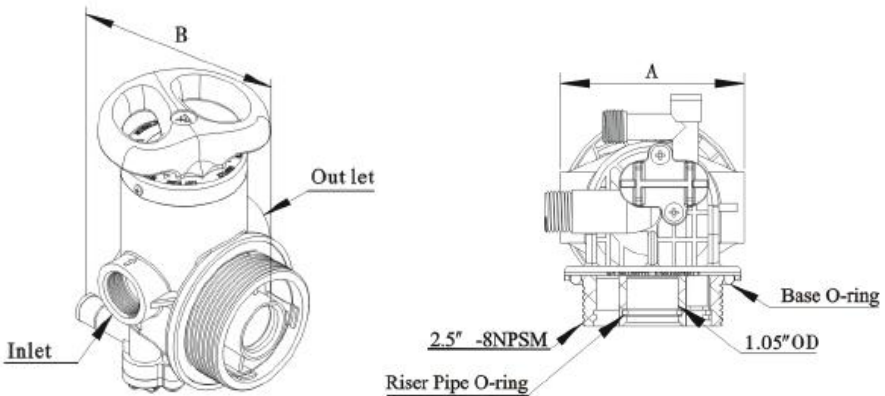

MODEL: F64A/F64B/F64C/N64D/N64F/F64AC/F64BC

A. Product dimension

Model	F64A	F64B	F64C	N64D	N64F	F64AC	F64BC
A max (mm)	126	94	94	200	182	126	94
B max (mm)	162	130.8	130.8	198	187.5	128.5	117

B. Technical Parameters

Model	Port Size					Flow Rate m ³ /h	Remark
	Inlet/Outlet	Drain Outlet	Brine Line Connector	Base	Riser Pipe		
F64A 61104/61204	1"F	1/2"M	3/8"M	2.5"-8NPSM	1.05"OD	4.5	Down-flow regeneration
F64B 61202	3/4"F	1/2"M	3/8"M	2.5"-8NPSM	1.05"OD	2	Down-flow regeneration
F64C 71202	3/4"F	1/2"M	3/8"M	2.5"-8NPSM	1.05"OD	2	Up-flow regeneration
N64D 61210	2"M	1"M	1/2"M	4"-8UN	1-1/2"D-GB	10	Down-flow regeneration
N64F 61206	1-1/2"M	3/4"M	1/2"M	4"-8UN	1.25"D-GB	8	Down-flow regeneration

F64AC 61204C	1"F	1/2"M	3/8"M	2.5"- 8NPSM	1.05"OD	4.5	Side-contr olled and down-flow
F64BC 61202C	3/4"F	1/2"M	3/8"M	2.5"- 8NPSM	1.05"OD	2	Side-contr olled and down-flow

**Notes: M— Male Thread F— Female Thread OD— Outer Diameter
D-GB— CN Standard Nominal Diameter**

The flow rate is related with designed flow rate, inlet pressure, media etc. The above data is only for reference.

1.5.Installation

A. Installation notice

Before the installation, please read the instruction carefully and prepared all the materials and tools that needed.

The installation of products and pipes must be operated by professionals to ensure normal use.

Perform installation according to the relative pipeline regulations and the specification of Water Inlet, Water Outlet, Drain Outlet, and Brine Line Connector.

B. Device location

- ①The closer filter or softer to the drain point, the better.
- ②Leave a certain space for operating and maintaining conveniently
- ③The brine tank should be close to the softener.
- ④Do not install the valve near hot resources or in the sunlight, rain and other factors that may result in damage to the product directly.
- ⑤Do not install the device, drain outlet and other pipes under environment where the temperature may drop below 5°C, or above 45°C.
- ⑥Please install the system in a place where damage is least likely to occur if a leak emerges.

C. Pipeline installation

- ① **Install control valve**

- As the Figure 1-1 shows, select the riser pipe with 26.7mm OD, glue the riser pipe to the bottom strainer and put it into the mineral tank, cut off the exceeding tube out of tank top opening. Plug the riser tube in case of mineral entering.
- Fill the mineral to the tank, and the height is accordance with the design code.
- Remove the tap covering on the central tube. Install the top distributor to the valve.
- Insert the riser tube through top strainer into control valve and screw tight control valve.

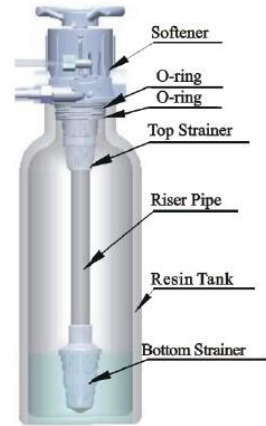

Figure 1-1

Note:

- The length of riser tube should be neither higher 2mm nor lower 5mm tank top opening height, and its top end should be rounded to avoid damage of O-ring inside the valve.
- Avoid floccules substance together with resin to fill in the mineral tank.
- Avoid O-ring inside control valve falling out while rotating it on the tank.

② Pipeline connection

- As the Figure 1-2 shows, a pressure gauge should be installed on the inlet pipe.
- Install a ball valve in inlet, outlet and pipelines.
- Install a check valve in water outlet.
- Inlet pipeline should be in parallel with outlet pipeline. Support inlet and outlet pipeline with fixed holder.

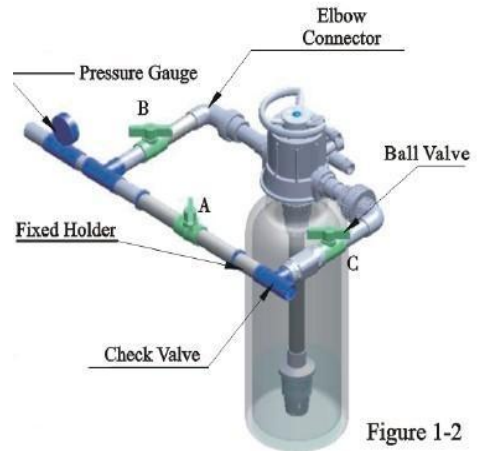

Figure 1-2

Note:

- If the water outlet or water tank is installed higher than control valve or parallel interlock system with multi-outlets, a liquid level controller must be installed in brine tank. Or else, the water in water outlet or water tank will flow backwards into brine tank when backwash.
- If making a soldered copper installation, do all sweat soldering before connecting pipes to the valve. Torch heat will damage plastic parts.
- When turning threaded pipe fittings onto plastic fitting, use care not to cross thread or broken valve.

③ Install drain pipeline

- a. Slide the drain hose connector into drain outlet.
- b. Insert drain line flow control into drain outlet.
- c. Screw drain hose connector into drain outlet, and lock it.
- d. Locate the drain hose well as the figure show.



Figure1-3

Attention:

●Control valve should be higher than the drain outlet, and be better not far from the drain hose.

●Be sure not connect drain with sewer, and leave a certain space between them, avoid wastewater be absorbing to the water treatment equipment, such as showed in the Figure1-3.

④ Connect brine tube

- a. As Figure 1-4 shows, slide 3/8" brine tube hose connector over end of brine tube.
- b. Insert the tube bushing into the brine hose.
- c. Insert the red brine line flow control washer into the brine line connector (The cone side should face to the valve).
- d. Tighten brine draw hose connector onto brine line connector.
- e. Connect the other end of brine tube with the brine tank. (The liquid level controller and air-blocker should be installed in the brine tank.)

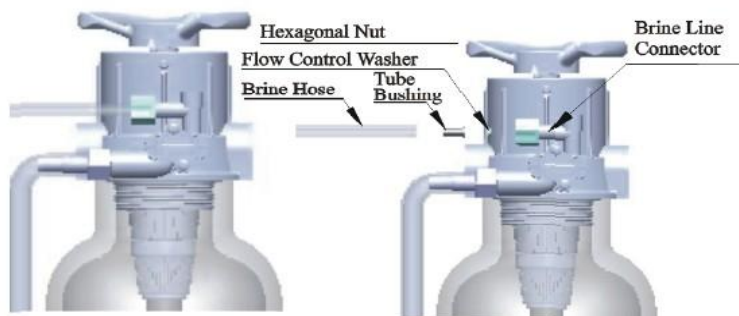

Figure 1-4

Attention: The brine tube and drain pipeline should not be bended or plugged.

2. Usage

2.1. Hand Wheel



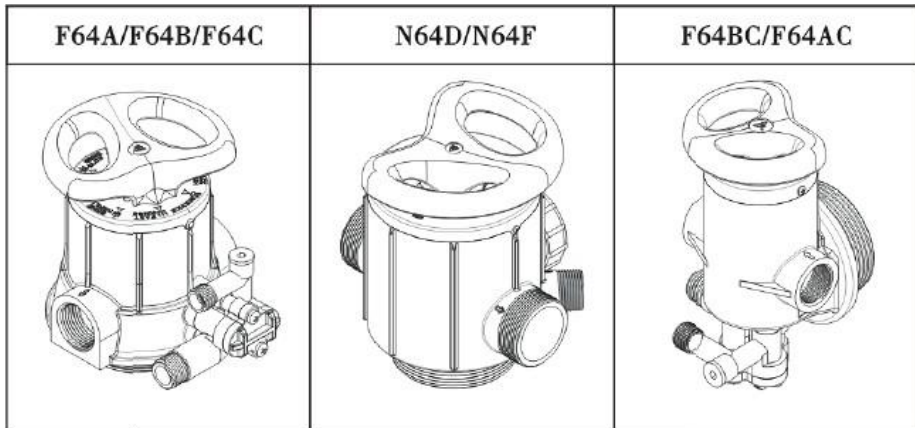

This series of control valve is operated by hand wheel to realize service, backwash, brine & slow rinse and fast rinse. As the following pictures show:



Attention:

- The handle or hand wheel can only be rotated but not pull up and down.
- The arrow of the hand wheel must direct to the exact arrow on the cover. Otherwise, it may result in mix water or the flow rate cannot reach the required volume.

2.2. Figure on Decoration Cover and its English Description

English	Figure	Description
SERVICE		In Service status
BACKWASH		In Backwash status
BRINE&SLOW R.		In Brine & Slow Rinse status
BRINE REFILL		In Brine Refill status
FAST RINSE		In Fast Rinse status

3. Applications

3.1. Working Flow Chart

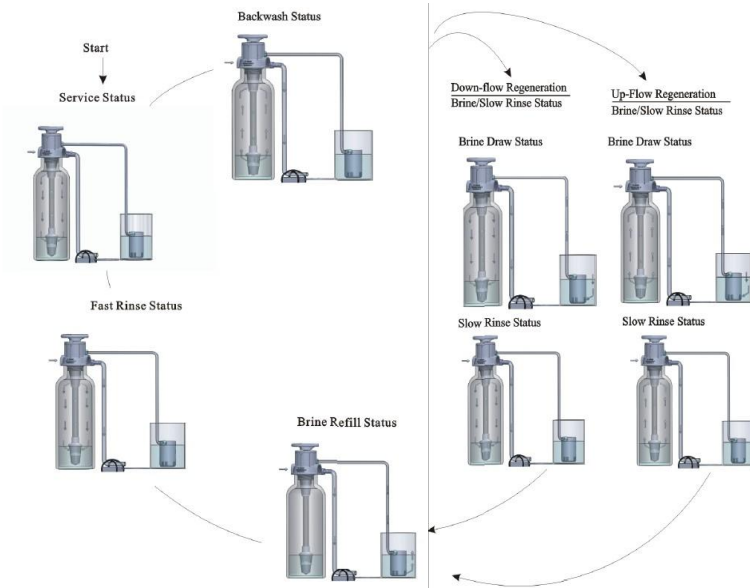

3.2. System Configuration and Flow Rate Curve

A. Product Configuration

Product configuration with tank, resin volume, brine tank and injector.

Tank Size (mm)	Resin Volume (L)	Flow Rate(t/h)	Brine Tank Size (mm)	The Minimum Salt Consumption for Regeneration (Kg)	Injector Model
φ180×1130	16	0.5	φ250×520	2.40	6302
φ205×1300	25	0.7	φ390×810	4.00	6303
φ255×1390	40	1.2	φ390×810	6.00	6305
φ300×1650	60	1.8	φ450×940	9.00	6306
φ355×1670	100	2.5	φ500×1060	15.00	6308
φ400×1670	120	3.5	φ550×1160	18.00	6309
φ450×1670	150	4.5	φ550×1160	22.50	6310
φ500×1800	200	5.0	φ740×1275	30.00	7401
φ600×1800	300	7.0	φ740×1275	45.00	7403
φ750×1800	450	11.0	φ840×1335	67.50	7404/7702

Attention: The flow rate calculation is based on linear velocity 25m/hr; the minimum salt consumption for regeneration calculation is based on salt consumption 150g / L (Resin).

B. Flow Rate Curve

F64A/F64AC

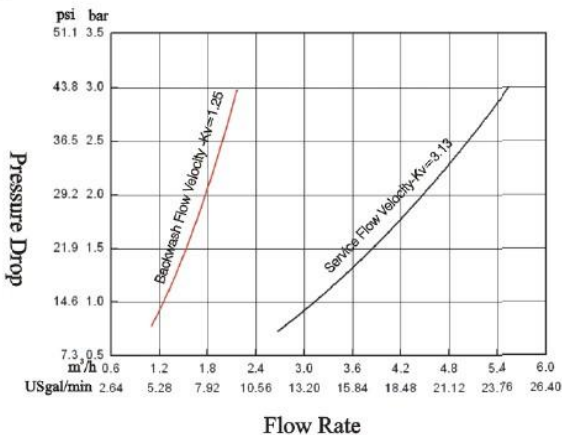

F64B/F64C/F64BC

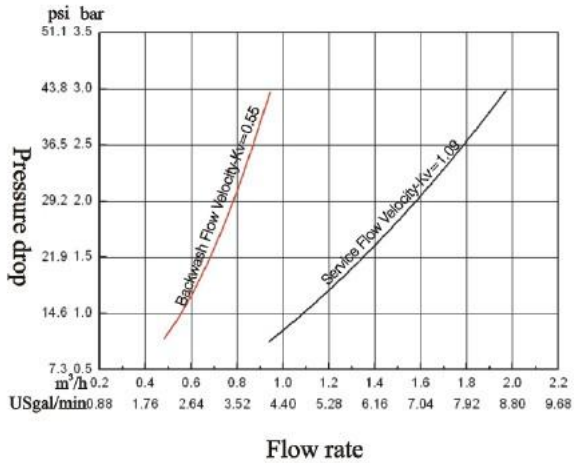

N64D

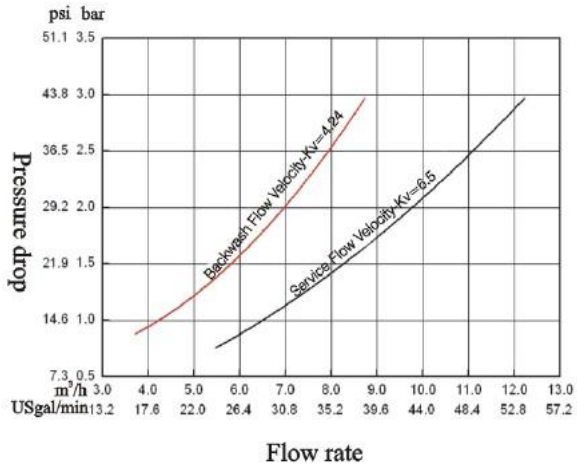

C. Injector Parameter Table

Inlet Pressure	Draw Rate (L/M)									
	6301 Coffee	6302 Pink	6303 Yellow	6304 Blue	6305 White	6306 Black	6307 Purple	6308 Red	6309 Green	6310 Orange
0.15	0.81	1.12	1.58	2.21	2.45	3.30	3.44	4.08	5.19	5.69
0.20	0.95	1.41	1.87	2.53	2.89	3.88	4.21	4.83	5.36	6.80
0.25	0.99	1.61	2.08	2.79	3.30	4.30	4.66	5.39	6.86	7.65
0.30	1.30	1.81	2.18	3.05	3.66	4.74	5.15	5.95	7.50	8.60
0.35	1.45	1.96	2.39	3.27	3.94	5.02	5.55	6.51	8.30	9.57
0.40	1.56	2.12	2.55	3.50	4.25	5.41	5.88	6.77	8.74	9.90

D. Configuration for Standard Injector and Drain Line Flow Control

Tank Dia mm	Injector Model	Injector color	Draw Rate	Slow Rinse	Brine Refill	DLFC	Backwash / Fast Rinse
			L/m	L/m	L/m		L/m
150	6301	Coffee	1.30	0.91	3.0	1#	4.7
175	6302	Pink	1.81	1.32	3.7	1#	4.7
200	6303	Yellow	2.18	1.73	3.8	2#	8.0
225	6304	Blue	3.05	2.14	3.3	2#	8.0
250	6305	White	3.66	2.81	4.3	3#	14.4
300	6306	Black	4.74	3.32	4.2	3#	14.4
325	6307	Purple	5.15	3.55	4.1	4#	22.8
350	6308	Red	5.95	4.0	4.0	4#	22.8
400	6309	Green	7.50	5.13	4.0	5#	26.4
450	6310	Orange	8.60	5.98	3.9	5#	26.4
500	7401	Coffee	16.0	10.56	23	1#	46.3
550	7402	Pink	20.0	13.88	28.2	2#	67
600	7403	Yellow	23.4	15.75	32.9	3#	71
750	7404	Blue	36.2	24.17	50.5	4#	75

Remark: Above data for the product configuration and relevant characteristics are only for reference. When put in practice, please subject to the different requirements of raw water hardness and application.

3.3. Parameter Settlement

① Service time T1

Water treatment capacity:

$$Q = V_R \times K \div Y_D \quad (\text{m}^3)$$

- Hardness of inlet water (mmol/L)
- Exchange factor (mmol/L) 400~1000.
Down-flow regeneration, take 400~750.
Up-flow regeneration, take 450~1000.
If the inlet water hardness is higher, the factor is smaller.
- Resin volume (m³)

By hours: $T1 = Q \div Q_h \quad (\text{Hour})$

- Water treatment capacity per hour (m³/h)
- Water treatment capacity (m³)

By days: $T1 = Q \div Q_d \quad (\text{Day})$

- Water treatment capacity per day (m³/d)
- Water treatment capacity (m³)

② Backwash time T2

It is subject to the turbidity of inlet water. The higher the turbidity is, the longer backwash time can be set. However, if the turbidity is more than 5FTU, it should be better to install a filter in front of the exchanger.

③ Brine & slow rinse time T3

$$T3 = (40 \sim 50) \times H_R \quad (\text{Min.})$$

In general, $T3 = 45 H_R \quad (\text{Min.})$

in this formula, H_R — Resin volume (m³)

④ Brine refill time T4

Down-flow regeneration: $T4 = 0.45 \times V_R \div \text{Brine refill speed} \quad (\text{Min.})$

Up-flow regeneration: $T4 = 0.34 \times V_R \div \text{Brine refill speed} \quad (\text{Min.})$

In this formula: V_R — Resin volume (m³)

The Brine refill speed is related to inlet water pressure. It is suggested to lengthen 1~2 minutes of calculated brine refilling time to make sure there is enough water in tank. (The condition is that there is a level controller installed in the brine tank)

⑤ Fast rinse T5

$$T5 = 12 \times H_R \quad (\text{Min.})$$

Generally, the water for fast rinse is 3~6 times of resin volume. It is suggested to be set 10~16 minutes, but subject to the outlet water reaching the requirement.

The calculation of parameters for each step is only for reference, the actual proper time will be determined after adjusting by water exchanger supplier.

3.4.Trial Running

After installing the multi-functional flow control valve on the resin tank with the connected pipes, please conduct the trial running as follows:

A. Close the inlet valve B & C, and open the bypass valve A. After cleaning the foreign materials in the pipe, close the bypass valve A. (As Figure 1-3 shows)

B. Fill the brine tank with the planned amount of water and adjust the air check valve. Then add solid salt to the tank and dissolve the salt as much as possible.

C. Switch hand wheel to Backwash position. Slowly open the inlet valve B to 1/4 position, making the water flow into the resin tank; you can hear the sound of air-out from the drain pipeline. After all air is out of pipeline, then open inlet valve B completely and clean the foreign materials in the resin tank until the outlet water is clean. It will take 8~10 minutes to finish the whole process.

D. Switch hand wheel to Brine & Slow Rinse position. After control valve finished sucking brine, then slow rinse start to work. The total time of brine and slow rinse is about 60~65 minutes.

E. Switch hand wheels to Brine Refill position. Brine tank is being refilled with water to the required level.

F. Switch hand wheel to Fast Rinse position. It takes about 10~15minutes. Take out some outlet water for testing, if the water hardness reach the requirement, and the chloridion in the water is almost the same compared with the inlet water,

G. Switch hand wheel to Service position. System start to running.

Note:

● If water inflow too fast, the media in tank will be damaged. When water inflow slowly, there is a sound of air emptying from drain pipeline.

● After changing resin, please empty air in the resin according to the above Step C.

● In the process of trial running, please check the water situation in all position, ensuring there are no resin leakages.

● The time for Backwash, Brine& Slow Rinse, Brine Refill and Fast Rinse position can be set and executed according to the calculation in the formula or suggestions from the control valve suppliers.

3.5. Usage

After being accomplished installation, parameter setting and trial running, the valve could be put into use. In order to ensure the quality of outlet water can reach the requirement, the user should complete the below works:

- ① Ensure that there is solid salt all the time in the brine tank in the course of using when this valve is used for softening.
- ② Test the outlet water and raw water hardness at regularly. When the outlet water hardness is unqualified, please switch hand wheel and the valve will temporary regenerate from step C to F again.
- ③ When the feed water hardness change a lot, refer to parameter settlement to adjust the cycle water capacity.

3.6. Trouble-Shooting

Problem	Cause	Correction
1. Softener supply hard water	A. Bypass valve is open or leaking. B. No salt in brine tank. C. Injector plugged. D. Insufficient water flowing into brine tank. E. Leak at O-ring on riser pipe. F. Internal valve leak. G. The bad quality of raw water. H. Shortage of resin.	A. Close or repair bypass valve. B. Add salt to brine tank and maintain salt level above water level. C. Change or clean injector. D. Check brine tank refill time. E. Make sure riser pipe is not cracked. Check O-ring and tube pilot. F. Change valve body. G. Increase the frequency of regeneration. H. Add resin to mineral tank and check the cause of resin leakages.

<p>2. Softener fails to draw brine.</p>	<p>A. Line pressure is lower than 0.2 MPa. B. Brine line is plugged. C. Brine line is leaking. D. Injector is plugged. E. Internal control leak. F. Drain line is plugged. G. Sizes of injector and DLFC not match with tank.</p>	<p>A. Increase line pressure. B. Clean brine line. C. Replace brine line. D. Clean or replace new parts. E. Replace valve body. F. Clean drain line flow control. G. Select correct injector size and DLFC according to the P20 requirements.</p>
<p>3. Pressure lost or iron in conditioned water.</p>	<p>A. Iron in the water supply pipe. B. Iron mass in the softener. C. Fouled resin bed. D. Too much iron in the raw water.</p>	<p>A. Clean the water supply pipe. B. Clean valve and add resin cleaning chemical, increase frequency of regeneration. C. Check backwash, brine draw and brine tank refill. Increase frequency of regeneration and backwash time. D. Iron removal equipment is required to install before softening.</p>
<p>4. Loss of resin through drain line.</p>	<p>A. Air in water system. B. Bottom strainer broken. C. Improperly sized drain line control.</p>	<p>A. Assure that well system has proper air eliminator control. B. Replace new bottom strainer. C. Check for proper drain rate.</p>
<p>5. Drain flows continuously.</p>	<p>A. Internal valve leak. B. The hand wheel is not rotated to the right position.</p>	<p>A. Check and repair valve body or replace it. B. Rotate the hand wheel to make sure the arrow must face to the exact arrow on the cover.</p>

<p>6. Salt water in soften water.</p>	<p>A. Foreign material in injector pr injector fails to work. B. Brine valve cannot be shut-off. C. Time of fast rinse too short.</p>	<p>A. Clean and repair injector. B. Repair brine valve and clean it. C. Extend fast rinse time.</p>
<p>7. Interrupted or irregular brine.</p>	<p>A. Water pressure too low or not stable. B. Injector is plugged or faulty. C. Air in resin tank. D. Floccules in resin tank during backwash.</p>	<p>A. Increase water pressure. B. Clean or replace injector. C. Check and find the reason. D. Clean the floccules in resin tank.</p>
<p>8. Water flow out from drain or brine pipe after regeneration.</p>	<p>A. Foreign material in valve which makes valve can't be closed completely. B. Hard water mixed in valve body. C. Water pressure is too high which result in valve doesn't get the right position. D. Under the Backwash position, the outlet line and brine line are connected.</p>	<p>A. Clean foreign material in valve body. B. Change valve core or sealing ring. C. Reduce water pressure or use pressure release function. D. install a check valve, solenoid valve in front of the outlet or install a liquid level controller in the brine tank.</p>
<p>9. Unit capacity decreases.</p>	<p>A. Unit fails to regenerate or regenerate not properly. B. Fouled resin bed. C. Raw water quality deterioration.</p>	<p>A. Regenerate according to the correct operation requirement. B. Increase backwash flow rate and time, and clean or change resin. C. Regenerate unit by manual temporary, then reset regeneration cycle.</p>

3.7. Assembly & Parts

F64A/F64B/F64C Structure Chart

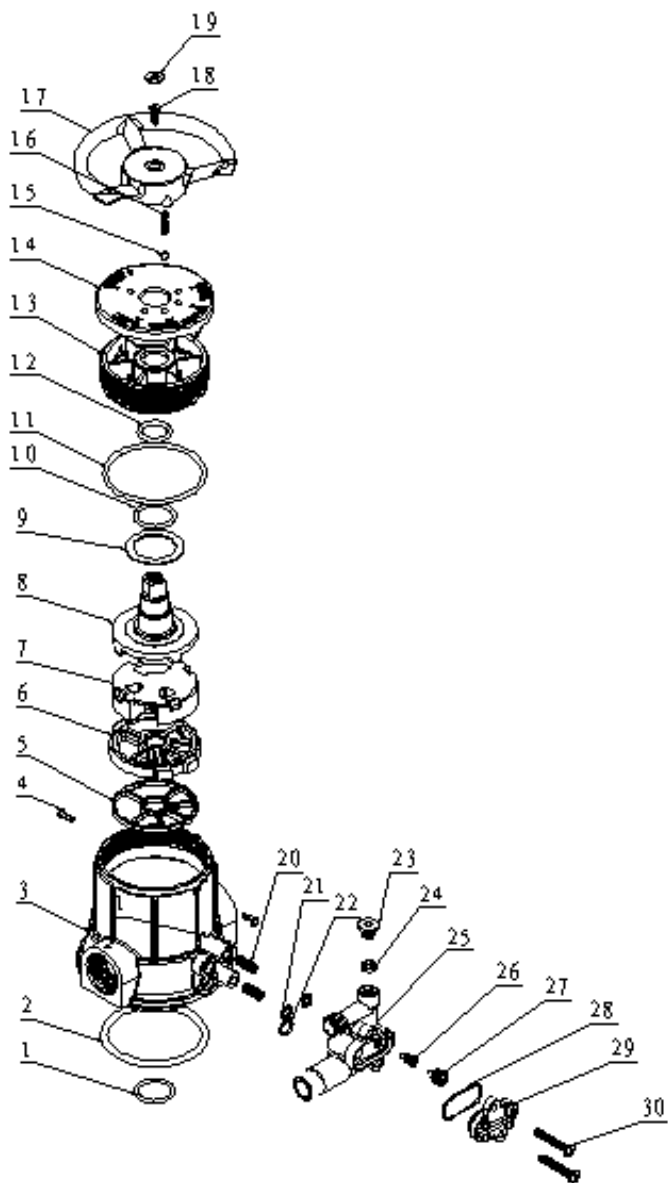

MODEL: F64A/F64B/F64C/N64D/N64F/F64AC/F64BC

F64A/F64B/F64C Component Name & Code

Item No.	Description	Part No.			Quantity
		F64A	F64B	F64C	
1	O-ring	8378078	8378078	8378078	1
2	O-ring	8378143	8378143	8378143	1
3	Valve Body (ABS+GF10)	5022010	5022012	5022014	1
	Valve Body(PPO+GF20)	5022009	5022011	5022013	
4	Screw, Cross	/	8909008	8909008	2
	Screw, Plastic	8993002	/	/	2
5	Seal Ring	8370002	8370025	8370034	1
6	Fixed Disk	8469001	8469012	8469015	1
7	Moving Disk	8459001	8459013	8459016	1
8	拨叉 Shaft	8258007	8258009	8258009	1
9	Anti-friction Washer	8216003	8216010	8216010	1
10	O-ring	8378115	8378078	8378078	1/2/2
11	O-ring	8378128	8378107	8378107	1
12	O-ring	8378113	/	/	1
13	Fitting Nut	8092003	8092007	8092007	1
14	Cover	8444007	8444008	8444009	1
15	Iron Bead	8271004	8271004	8271004	1
16	Spring	8282003	8282003	8282003	1
17	Hand Wheel	8253009	8253011	8253011	1
18	Screw, Cross	8909014	8909014	8909014	1
19	Label	8860001	8860001	8860001	1
20	Inserts	8947002	8947002	8947002	2
21	O-ring	8378016	8378016	8378016	2
22	O-ring	8378012	8378012	8378012	1
23	Plug	8323002	8323002	8323002	1
24	Seal Ring	8370003	8370003	8370003	1
25	Injector Body	8008001	8008001	8008001	1
26	Throat, Injector	8467001-010	8467001-010	8467001-010	1
27	Nozzle, Injector	8454001-010	8454001-010	8454001-010	1
28	O-ring	8378025	8378025	8378025	1
29	Cover, Injector	8315001	8315001	8315001	1
30	Screw, Cross	8902017	8902017	8902017	2

F64D/F64F Structure Chart

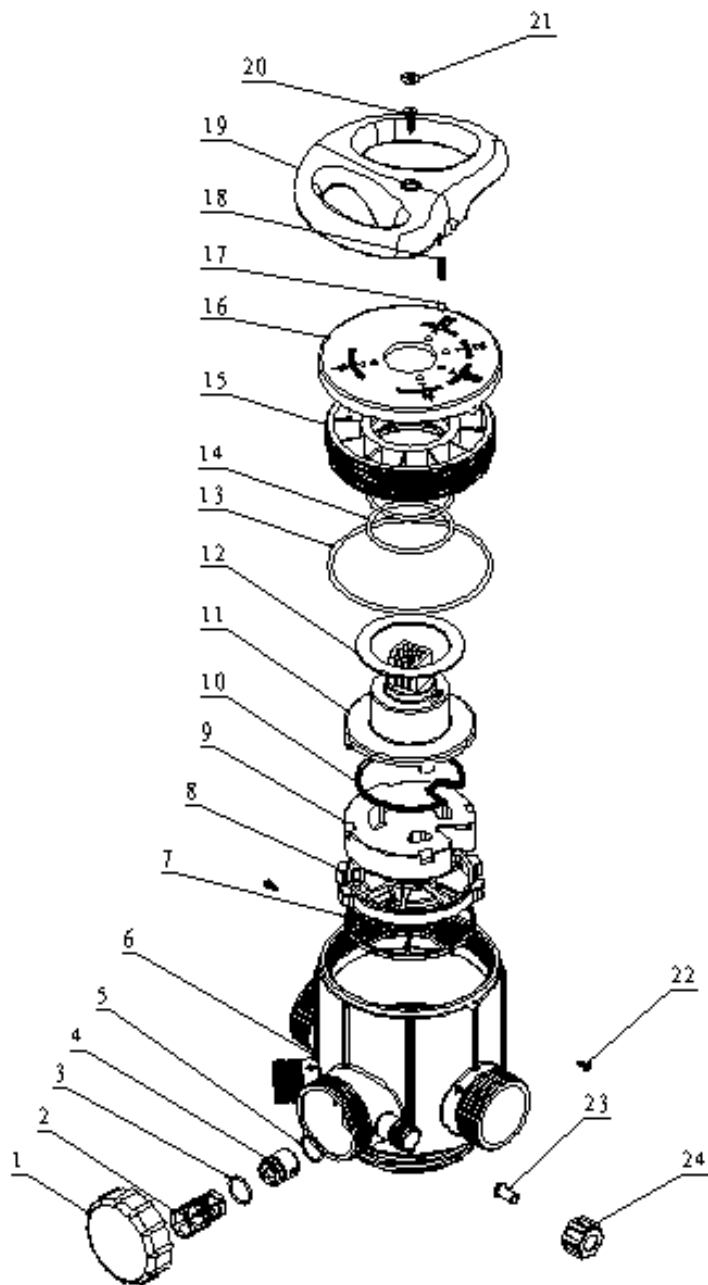

F64D/F64F Component Name & Code

Item No.	Description	Part No.		Quantity
		F64D	F64F	
1	Cover, Injector	8315006	8315013	1
2	Nozzle, Injector	8454011~016	8454011~016	1
3	O-ring	8378024	8378024	1
4	Throat, Injector	8467011~016	8467011~016	1
5	O-ring	8378021	8378021	1
6	Valve Body(ABS+GF10)	8022033	8022035	1
	Valve Body(PPO+GF10)	8022034	8022036	
7	Seal Ring	8370016	8370021	1
8	Fixed Disk	8469010	8469011	1
9	Moving Disk	8459011	8459012	1
10	Seal Ring	8370018	8370023	1
11	Shaft	8258005	8258012	1
12	Anti-friction Washer	8216006	8216006	1
13	O-ring	8378133	8378130	1/2
14	O-ring	8378110	8378110	2
15	Fitting Nut	8092005	8092006	1
16	Cover	8444010	8444011	1
17	Iron Bead	8271004	8271004	1
18	Spring	8282003	8282003	1
19	Hand Wheel	8253041	8253041	1
20	Screw, Cross	8909018	8909018	1
21	Label	8860001	8860001	1
22	Screw, Cross	8909008	8909008	2
23	Tube	8457025	8457025	1
24	Hexagonal Nut	8940016	8940016	1

F64BC/F64AC Structure Chart

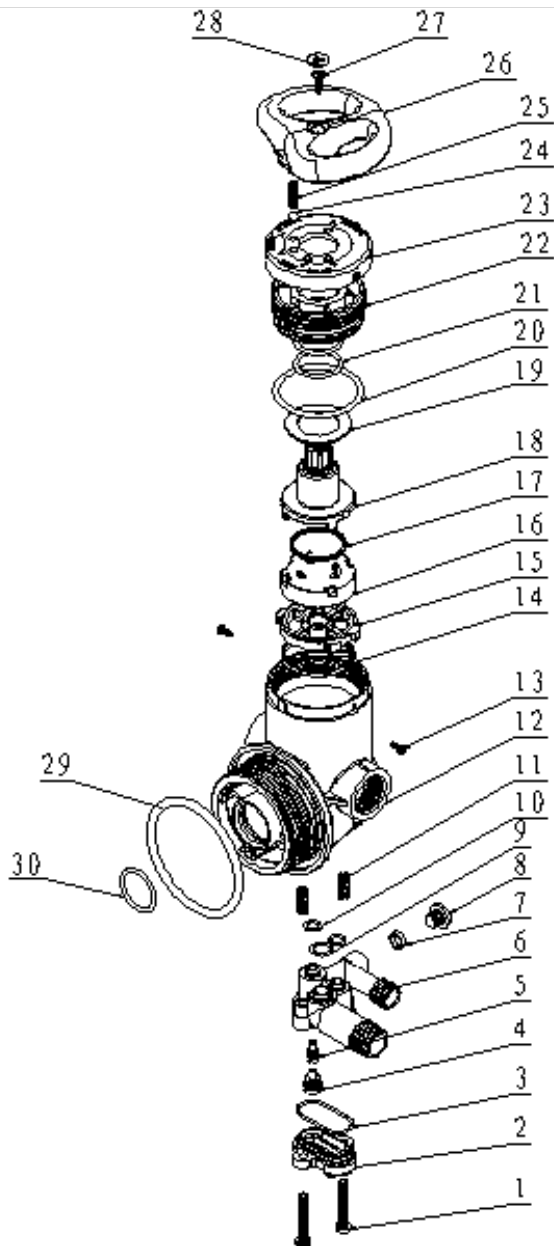

MODEL: F64A/F64B/F64C/N64D/N64F/F64AC/F64BC

F64AC/F64BC Component Name & Code

Item No.	Description	Part No.		Quantity
		F6AC	F64BC	
1	Screw, Cross	8902017	8902017	2
2	Cover, Injector	8315001	8315001	1
3	O-ring	8378025	8378025	1
4	Nozzle, Injector	8454001~010	8454001~010	1
5	Throat, Injector	8467001~010	8467001~010	1
6	Injector Body	8008001	8008001	1
7	Seal Ring	8370003	8370003	1
8	Plug	8323002	8323002	1
9	O-ring	8378012	8378012	1
10	O-ring	8378016	8378016	2
11	Inserts	8947002	8947002	2
12	Valve Body(ABS+GF10)	/	8022016	1
	Valve Body(PPO+GF20)	8022017	8022015	
13	Screw, Cross	8909008	8909008	2
14	Seal Ring	8370002	8370025	1
15	Fixed Disk	8469001	8469012	1
16	Moving Disk	8459001	8459013	1
17	Moving Seal Ring	/	8370053	1
18	Shaft	8258007	8258009	1
19	Anti-friction Washer	8216003	8216010	1
20	O-ring	8378128	8378107	1
21	O-ring	8378113	8378078	1/2
		8378115	/	1
22	Fitting Nut	8092003	8092007	1
23	Cover	8444007	8444008	1
24	Iron Bead	8271004	8271004	1
25	Spring	8282003	8282003	1
26	Hand Wheel	8253010	8253011	1
27	Screw, Cross	8909014	8909014	1
28	Label	8860001	8860001	1
29	O-ring	8378143	8378143	1
30	O-ring	8378078	8378078	1

4. Warranty Card

Dear client:

This warranty card is the guarantee proof of RUNXIN brand multi-functional flow control valve. It is kept by client self. You could get the after-sales services from the supplier which is appointed by RUNXIN manufacturer. Please keep it properly. It could not be retrieved if lost. It couldn't be repaired free of charge under the below conditions:

1. Guarantee period expired. (One year).
2. Damage resulting from using, maintenance, and keeping that are not in accordance with the instruction.
3. Damage resulting from repairing not by the appointed maintenance personnel.
4. Content in guarantee proof is unconfirmed with the label on the real good or be altered.
5. Damage resulting from force majeure.

Product Name	 Multi-functional Flow Control Valve for Water Treatment Systems				
Model			Code of Valve Body		
Purchase Company Name			Tel/Cel.		
Problem					
Solution					
Date of Repairing		Date of Accomplishment		Maintain Man	

MODEL: F64A/F64B/F64C/N64D/N64F/F64AC/F64BC

When product need warranty service, please fill in the below content and sent this card together with the product to the appointed suppliers or Runxin company.

End-user Company Name		Tel/Cel.	
Purchase Company Name		Tel/Cel.	
Model		Code of Valve Body	
Tank Size ϕ ×	Resin Volume L	Raw Water Hardness mmol/L	
Water Source: ground-water <input type="checkbox"/> Tap Water <input type="checkbox"/>	Water Treatment Capacity m^3	Backwash Time Min.	
Brine & Slow Rinse Time Min.	Brine Refill Time Min.	Fast Rinse Time Min.	
Problem Description			

WENZHOU RUNXIN MANUFACTURING MACHINE CO., LTD.

ADD: Jinger Road, Shatou Group, Linjiang, Lucheng District,
Wenzhou, Zhejiang, China

TEL: 0577-88635628 88576511 FAX: 0577-88633258

<http://www.run-xin.com> Email:sales@run-xin.com